



Institute for Sustainability and
Innovation in Structural Engineering

ISISE Stats & Highlights

2022



ISISE in Numbers



Concluded PhD Theses

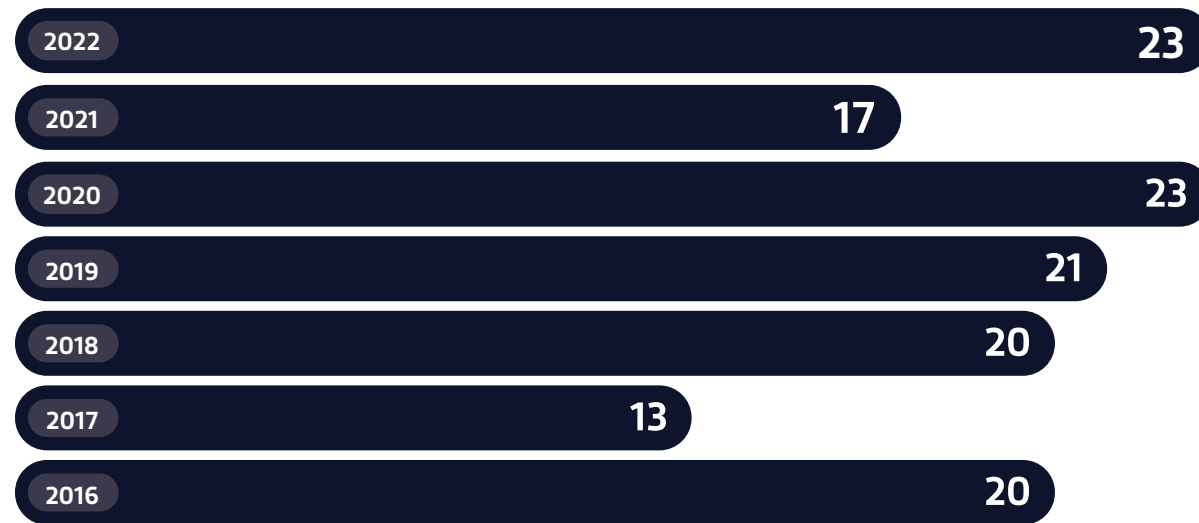

Articles Published in WoS Journals

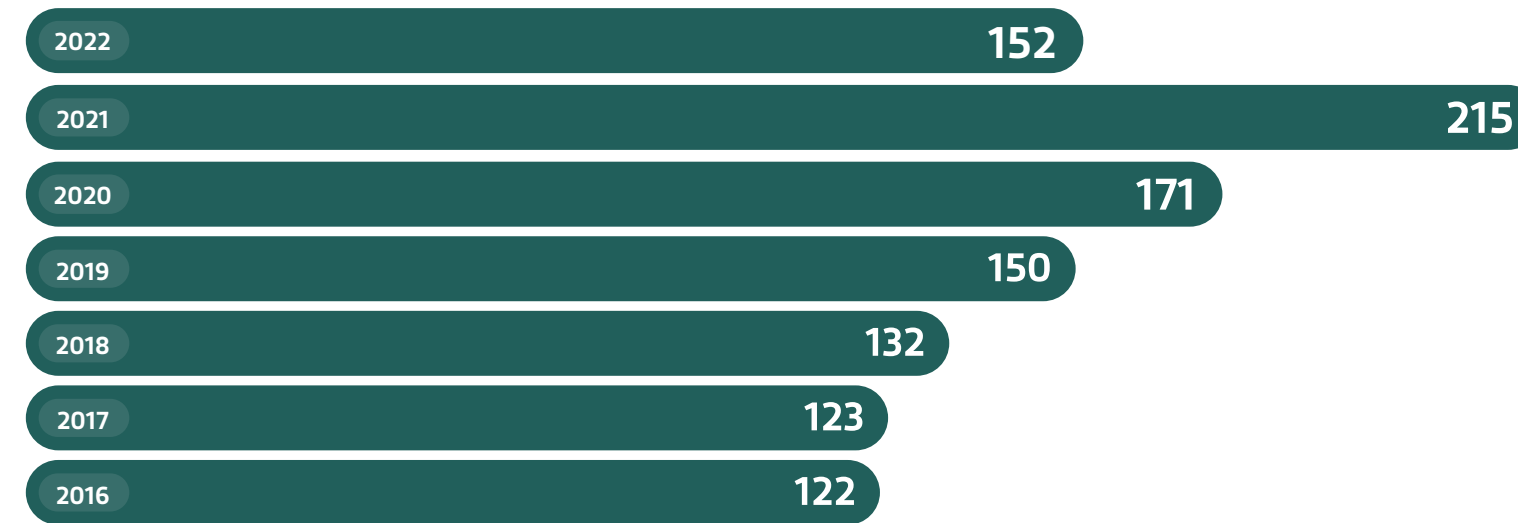

Contracted Project Funding (M€)

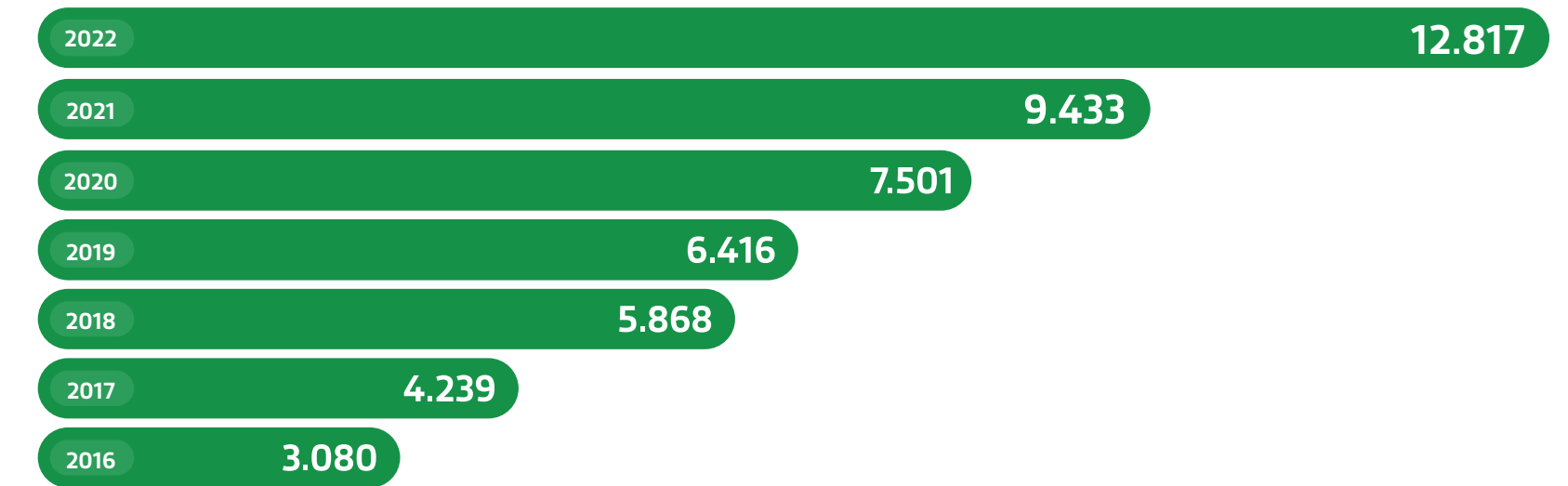

Members

- PhD students
- Faculty
- Postdocs

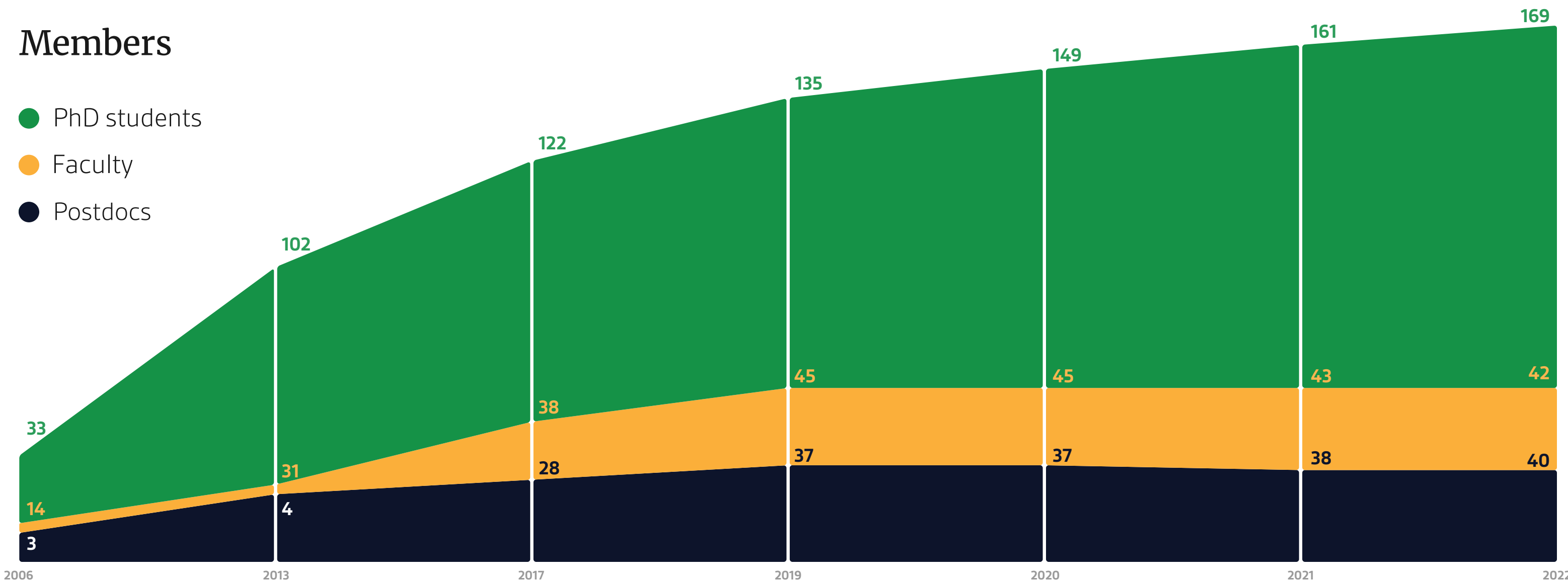

Funding Distribution in 2022

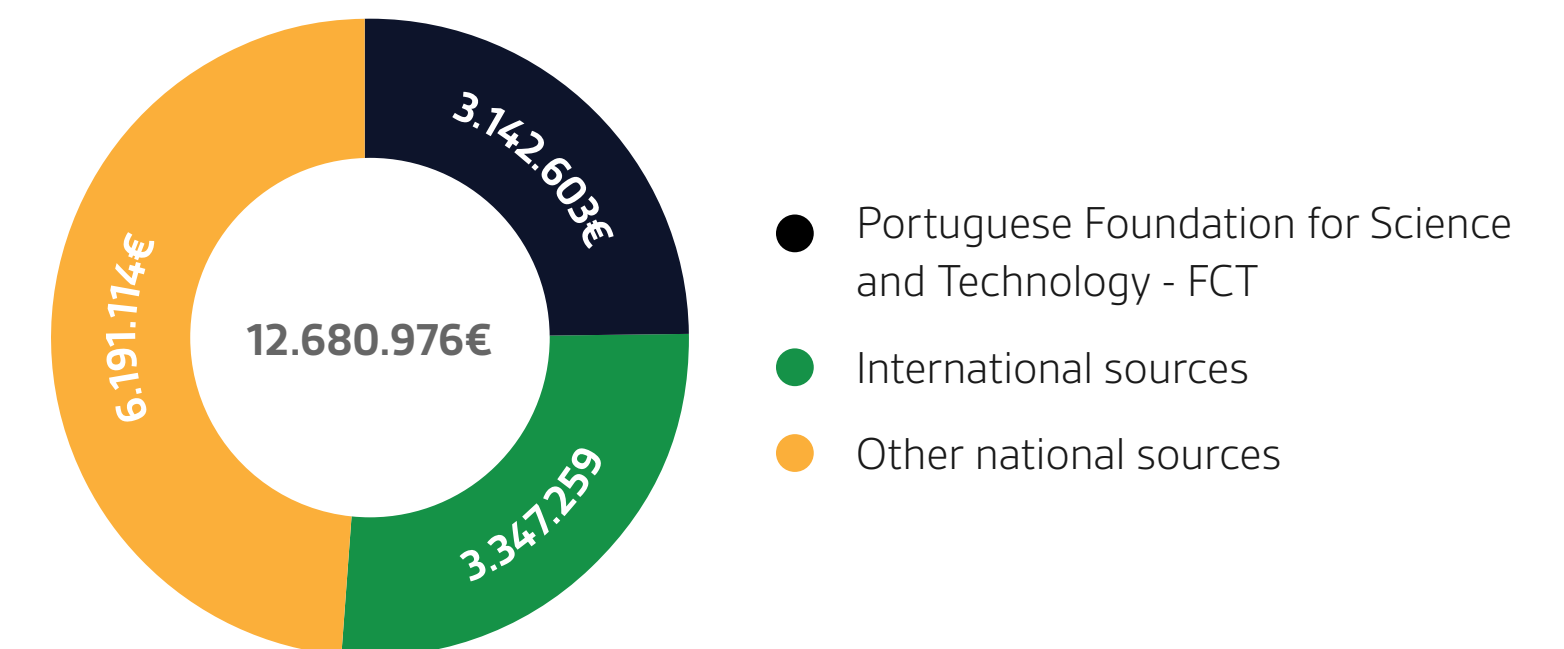

International Alumni



MSc Alumni: 98 Countries (89% of the world population)

America

Argentina
Bolivia
Brazil
Canada
Chile
Colombia
Costa Rica
Dominican Republic
Ecuador
Guatemala
Mexico
Nicaragua
Paraguay
United States of America
Venezuela

Africa

Algeria
Angola
Cameroon
Ethiopia
Ghana
Kenya
Liberia
Libya
Mauritania
Morocco
Nigeria
Sudan
Tanzania
Tunisia
Zambia
Zimbabwe

Asia

Afghanistan
Bangladesh
Bhutan
China
Georgia
India
Iran
Iraq
Israel
Japan
Jordan
Kazakhstan
Kyrgyzstan
Lebanon
Malaysia
Myanmar
Nepal
Pakistan
Palestine
Philippines
Singapore
South Korea
Syria
Thailand
Vietnam

Europe

Albania
Austria
Belgium
Bulgaria
Croatia
Czech Republic
Finland
France
Germany
Greece
Hungary
Ireland
Italy
Lithuania
Macedonia
Moldavia
Netherlands
Poland
Portugal
Romania
Serbia
Slovakia
Slovenia
Spain
Sweden
Ukraine
United Kingdom

Oceania

Australia
New Zealand

Intercontinental States

Azerbaijan
Cyprus
Egypt
Indonesia
Turkey
Russia

PhD Alumni: 52 Countries (70% of the world population)

America

Bolivia
Brazil
Chile
Colombia
Costa Rica
Ecuador
Guatemala
Mexico
Peru
United States of America

Africa

Angola
Cape Verde
Ethiopia
Kenya
Morocco
Mozambique
Nigeria
Sudan
Tunisia
Rwanda

Asia

Afghanistan
China
Iran
Iraq
Jordan
Lebanon
Myanmar
Pakistan
Syria
Yemen

Europe

Albania
Belgium
Bulgaria
Croatia
Czech Republic
France
Germany
Hungary
Italy
Montenegro
Poland
Portugal
Romania
Serbia

Intercontinental States

Spain
Ukraine

Cyprus
Indonesia
Turkey

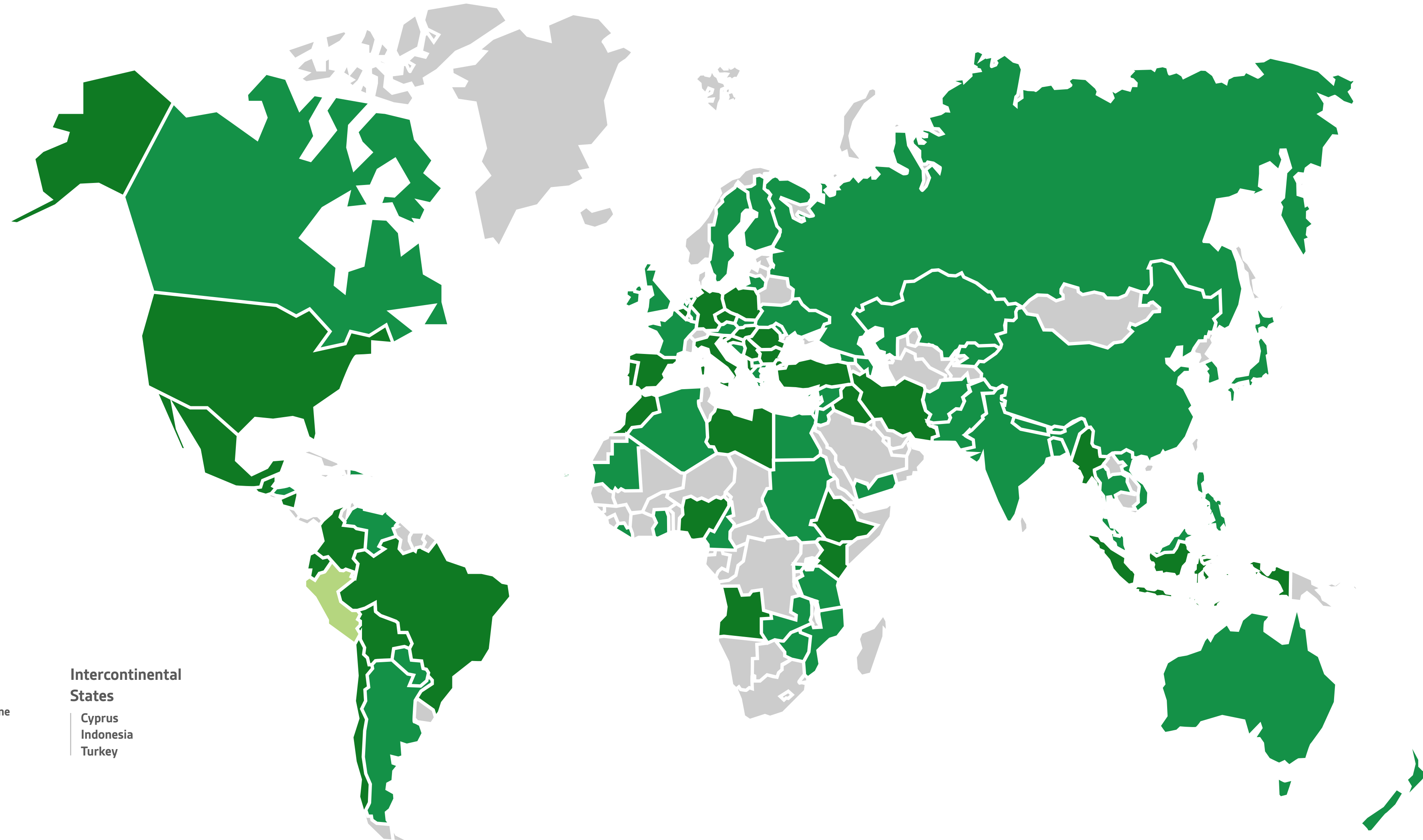



DigitalSteel

Promoting the Digitization of processes in SMEs in the Steel and Composite Construction sector

The project promoted by CMM, aimed the training and qualification of SMEs (small and medium-sized companies) in the sector of Steel and Composites Structures in the domain of digitalization of their processes, speeding up their transition to the 4.0 Industry paradigm and enhancing their international growth in markets with greater added value. ISISE-UC worked close with CMM within the scope of the project.



One of the aspects in which ISISE-UC collaborated was in the development of a digital platform, which allows companies, through the answer to a set of questions, to position themselves on a scale of BIM maturity. Depending on the level, the company gets a set of recommendations to implement in order to improve its performance in these domains.

Furthermore, ISISE-UC was also involved in the development of a platform that embodies a Pool of Specialized Technicians, in which each professional can provide information about their skills, experience and works developed in the BIM domain. The purpose is for the platform to work as a catalogue of Specialized Technicians to which the companies have access in order to strengthen their competencies and internal qualifications in these domains.

Finally, ISISE-UC also collaborated in the development of the Maturity BIM Seal, a distinction to communicate the level of BIM maturity of SMEs, thus giving credibility to their efforts developed within this aim. It is intended that this Seal allows the identification and positioning of each SME at the international and National levels.

For additional information, consult digitalsteel.pt where you can access and find detailed information about the identified resources.



www.digitalsteel.pt





ShakingTable

New lab facility to perform dynamic tests at the UMinho

The 1D shaking table, installed at the structural lab of the University of Minho, aims to perform dynamic tests at full and reduced-scaled experimental models. This new lab facility allows to simulate the seismic action and evaluate the seismic performance of unstrengthened and strengthened structures.

The shake table has one degree-of-freedom and 2.90 x 2.90 m² in plan. The steel platform was designed to present a rigid body behaviour (imperfections and deformations less than 0.1 mm) for the lowest mass (about 3 tons). It is supported on two linear bearing rails with three roller runner blocks each. The roller runner blocks are fixed to a base made of steel, which is fixed to the reinforced concrete slab of the laboratory.

The hydraulic system of the shaking table is composed of: (1) two main pump groups (145 l/min of maximum flow each); (2) two accumulators (50 l each); (3) one servo actuator; (4) one heating/cooling and filtering group; (5) one electric board.

The servo actuator has a maximum static and dynamic force of 290 kN and 312 kN (280 bar), respectively, a useful stroke of 250 mm (+/- 125 mm), an operating range of 0-50 Hz, 512 kg of mass, 170 mm of piston diameter, two hinges and it is fixed to the reinforced concrete reaction wall of the laboratory.



The shaking table allows to test experimental models with a maximum mass of 3 tons, applying dynamic actions with 5 g, 85 cm/s and +/- 125 mm of maximum acceleration, velocity and displacement, respectively, and 50 Hz of maximum frequency.

The control system is composed of: (1) two chassis; (2) 8 input analog channels; (3) 16 input and 16 output digital channels; (4) one accelerometer and one LVDT to measure the acceleration and displacement signals of the shaking table; (5) control loop executed deterministically on the controller's FPGA; (6) software for the control system and acquisition and processing of signals.

The control system allows to connect external sensors, such as accelerometers, LVDT's and strain gauges, to measure the response of the experimental models.

The shaking table includes also a Digital Image Correlation (DIC) system composed of 6 cameras connected to the control system by a trigger, which allows measuring the dynamic behaviour of the experimental models. The main outputs of the DIC system are the high-precision displacement contours over time and a 3D-digital model with deformations of the experimental model (accuracy: ~0.15-0.015 mm).





LightSlab

Development of innovative slab solutions using sandwich panels

The Lightslab project aimed at developing a new structural system for slabs, based on sandwich panels and involved the University of Minho (both the Civil Engineering and Polymer Engineering Departments) and Ferpainel S.A., as the consortium.

A sustainable future for the building industry requires changes in the current construction methods. Therefore, in this project, a new flooring system based on sandwich panels for applications in building rehabilitation and modular construction was developed.

The work involved: (i) conception and optimization of the structural system; (ii) experimental characterization of different materials; (iii) conception, development and characterization of different adhesive and mechanical connections; (iv) construction and characterization of prototypes; (v) development of design tools.

The developed floor system is lighter, more economical and less polluting than any solution currently available on the market. The panel's architecture includes a low-density core material reinforced with cold-formed steel sheets.

The design of the panel was optimized by means of genetic algorithms to minimize mass, cost and environmental impacts.

A comprehensive experimental campaign was carried out on the individual materials, prototypes and large-scale specimens.

Based on experimental results, numerical analyses were developed in order to perform parametric studies.

Design tools were developed for different geometries and load configurations to help practitioners and foster the application of sandwich panels in civil engineering.

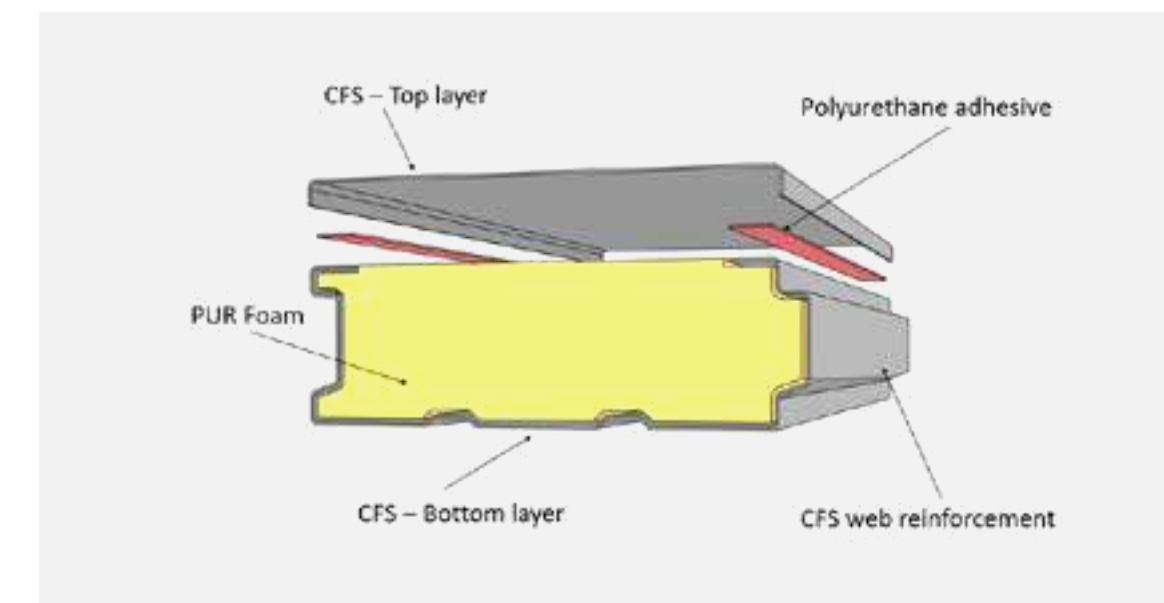

Panel's architecture

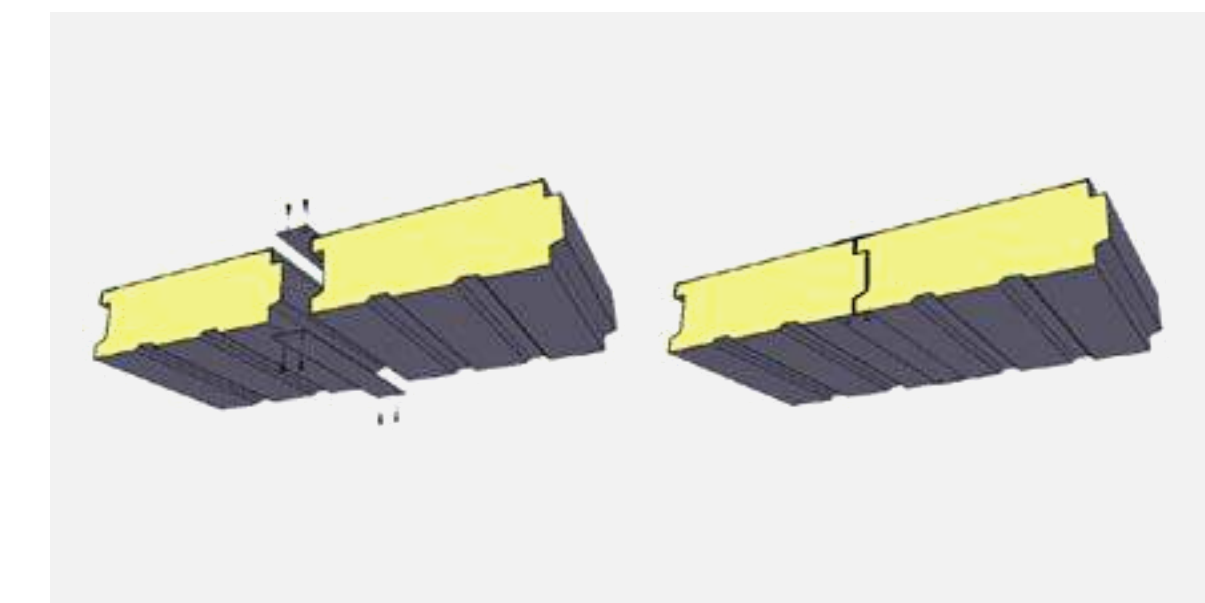

Example of connection between adjacent panels

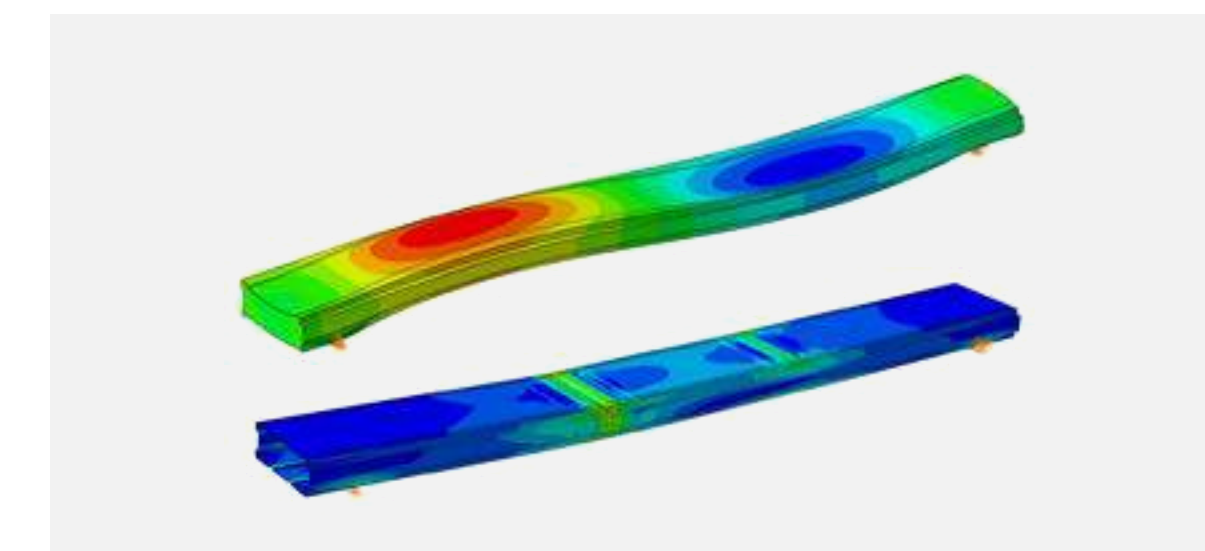
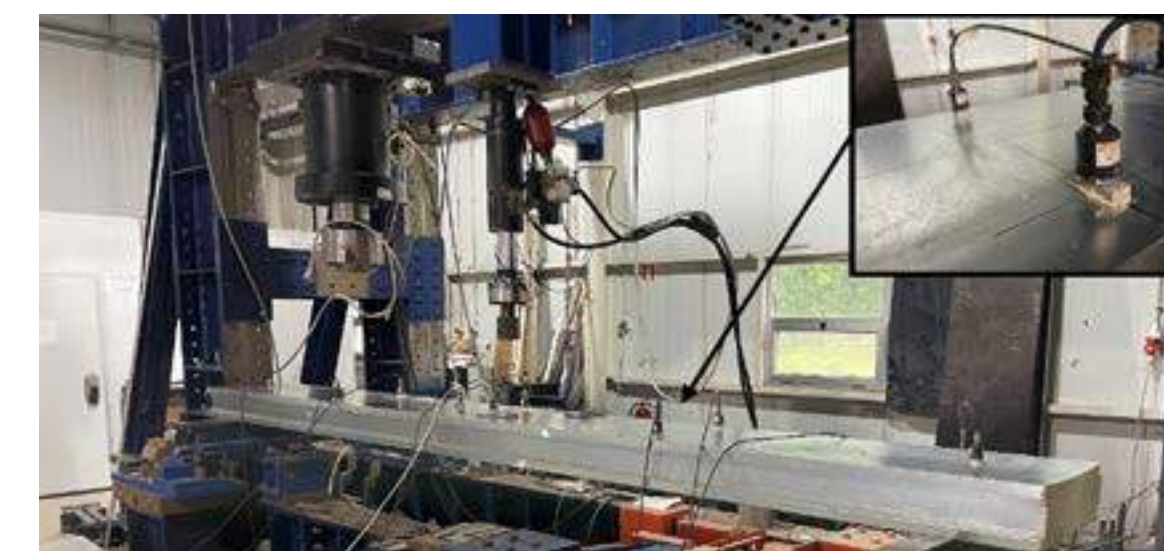

Numerical analyses of experimental tests on large-scale panels



ZeroSkin+

Integration of the photovoltaic system in the prefabricated module solution

Development of a 3D printed modular panel for holistic renovation of residential buildings, based on recycled plastic and natural materials

The energy renovation of residential buildings is today a primary concern and objective at the European level, essential to support the energy transition to reach carbon neutrality by 2050. Furthermore, the production of plastic has been growing steadily over the last years, and Europe is the second-largest producer of this material. In Portugal, the low recycling rates – only a third of the post-consumed plastic waste is recycled – aggravates the environmental problems and represents a valuable waste of resources.

In this context, the ZeroSkin+ project aims to develop an innovative prefabricated modular system for energy renovation of Portuguese residential buildings and improve the structural performance to attend to seismic requirements. The solution, aims to enhance the buildings' energy efficiency, reducing energy costs and embodied carbon. Both inner and outer panels will be 3D printed with recycled plastic as the primary panel material, and the support structure in steel to improve the seismic performance of the building.

Dividing into inner and outer panels increases the possibility of optimising the recycling plastics with different characteristics.

While the outer panel needs to meet requirements for UV radiation protection, rain, and mechanical resistance, the inner panel only needs to improve thermal performance.

Therefore, the inner panel allows a broader use of recycled thermoplastics that does not need to meet the outer panel's requirements.

The use of additive manufacturing (AM) can create high-precision complexes and customisable volumes in an automatised manner, allowing optimisation of the efficiency of the material used while increasing the thermal and mechanical performance.

Therefore, extensive experimental laboratory tests were conducted using twelve geometries and different densities to quantify the thermal resistance and mechanical variation inherent in 3D printing configuration.

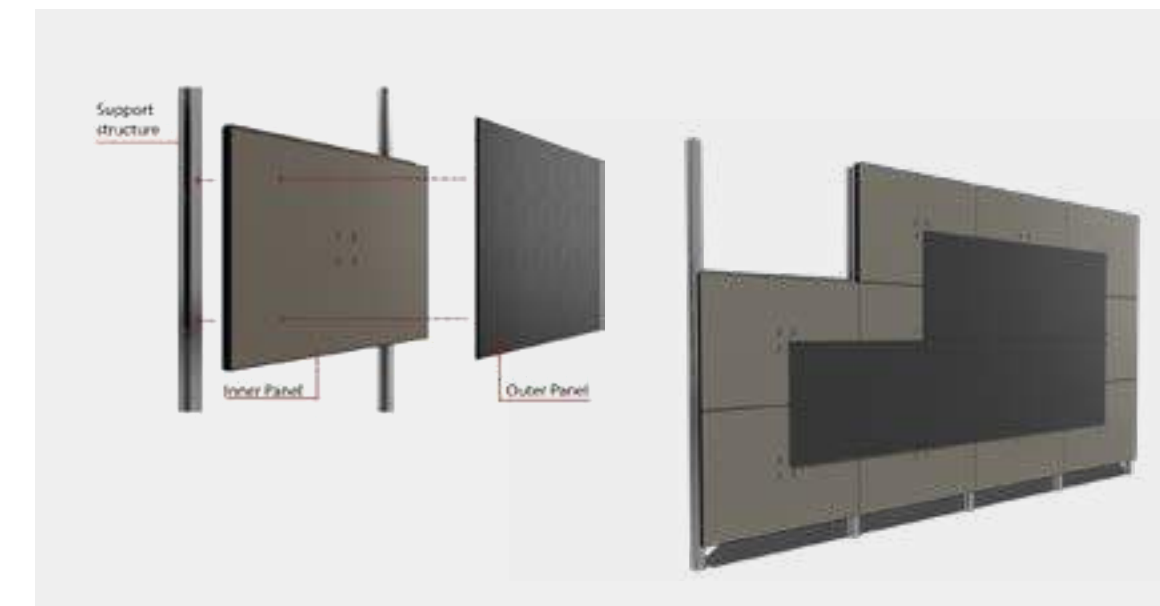

ZeroSkin+ prefabricated module solution for energy renovation of residential buildings. It includes a rigid polymer for coating and an elastomeric polymer for connecting the panels. The steel frame will support the panel on the building's facade.

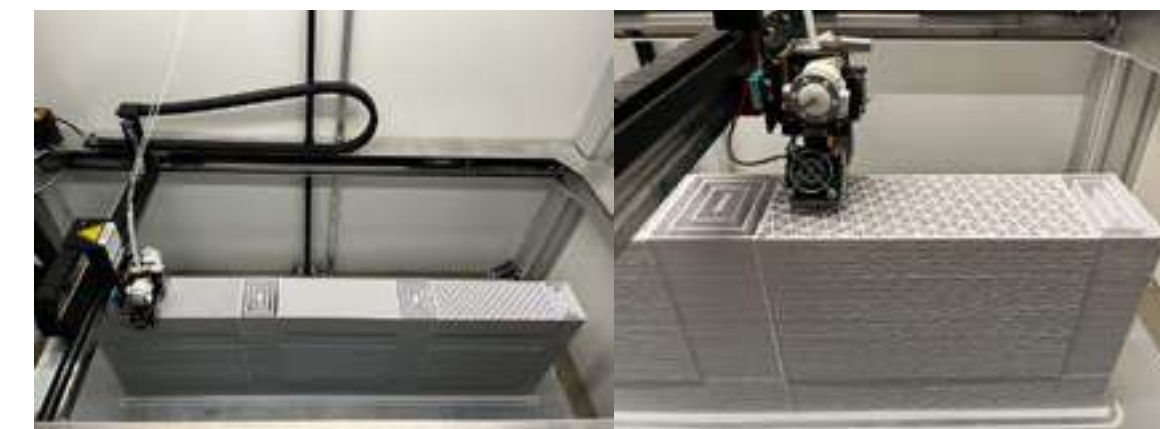

3D printing process of a set of samples.

The best results were achieved for the concentric and Hilbert curve geometries with a thermal conductivity of 0.057 W/(m.K) and 0.074 W/(m.K) using 25% of infill density, respectively. Since the thermal conductivity of air is lower than the thermoplastic, lower densities provide better thermal performance. Currently, lower-density samples are being tested to improve performance.

The ZeroSkin+, led by ISISE, involves three other research groups, the IPC (Institute for Polymers and Composites), the CMEMS (Centre for Electromechanical Systems), and CENTRO ALGORITMI.

Each group will contribute to developing the modular system, which includes the panel element fixed into a steel frame structure.

Future activities involve full-scale printing prototypes and integrating a photovoltaic system in the panel to facilitate the building to achieve the nZEB level. A digital version of the prefabricated modular system will be developed, in the context of construction 4.0, to improve the integration between the BIM models and the fabrication machines.

ZeroSkin+ prefabricated module solution for energy renovation of residential buildings. It includes a rigid polymer for coating and an elastomeric polymer for connecting the panels. The steel frame will support the panel on the building's facade.

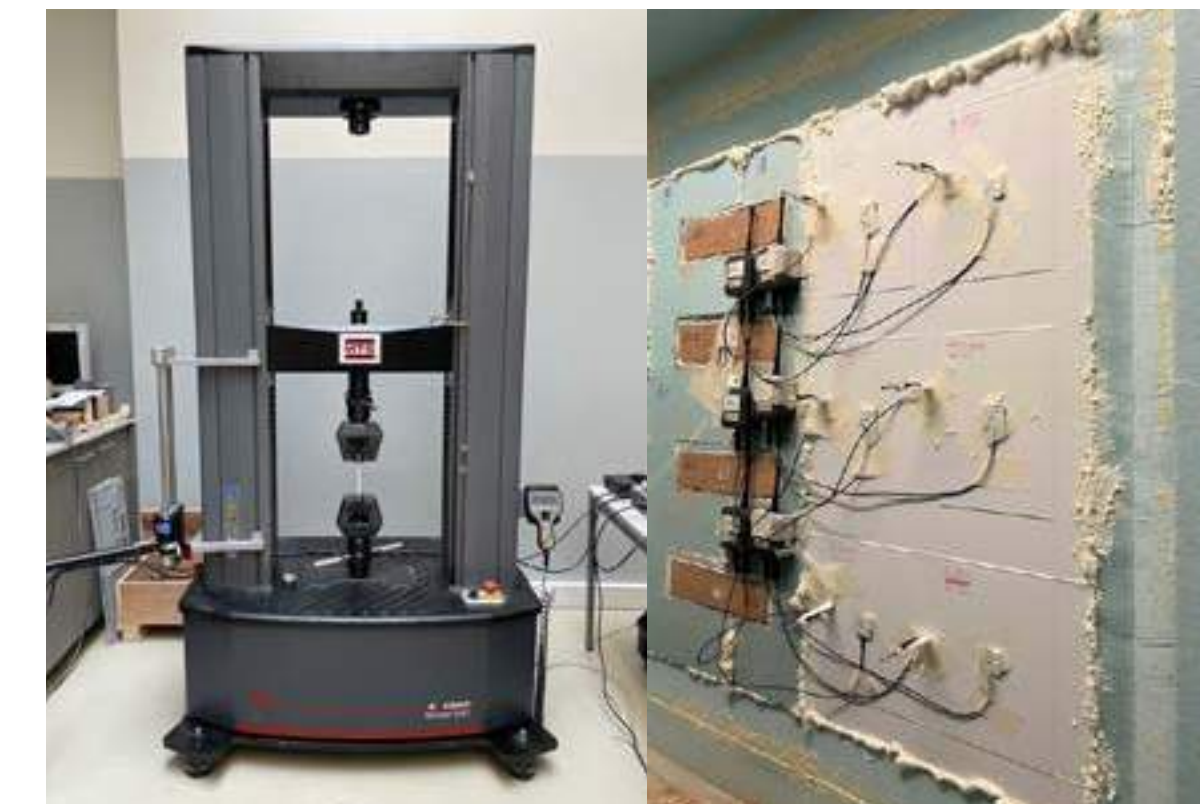

Thermal tests (left) and mechanical tests (right)

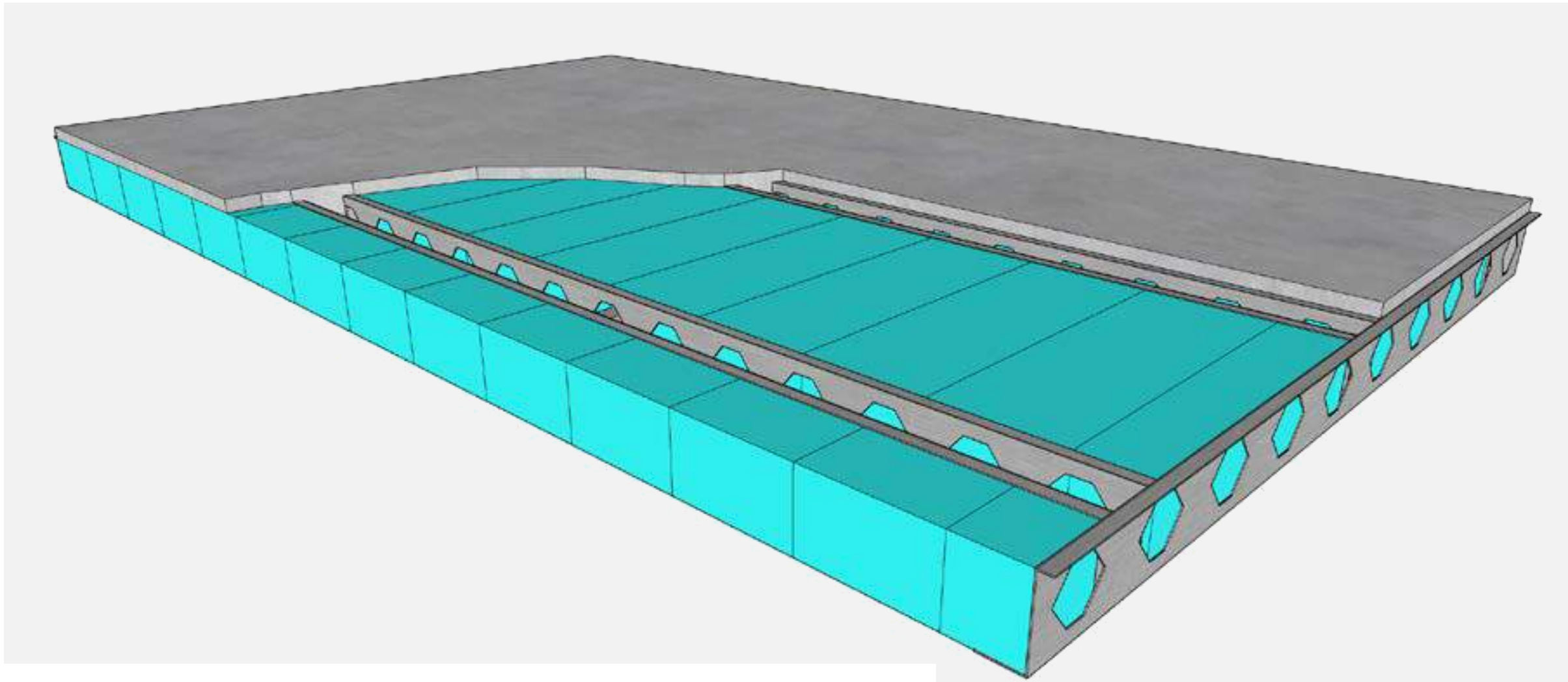

PreSlabTec

Innovative construction system for fully prefabricated lightweight slab of high behavioural performance, financed by ANI (FEDER through the Operational Program for Competitiveness and Internationalization (POCI))

In this project a new pre-fabricated lightweight slab system (patent PT116162) was developed, where the relatively high post-cracking tensile capacity of steel fibre-reinforced concrete (SFRC) is combined with the high ductility and tensile strength of optimized shape profiles made by cold-formed steel sheets for a synergistic result in terms of structural performance.

The SFRC fills the longitudinal steel profiles (girders) that have openings in the web for materializing SFRC shear mechanisms that provide very high shear resistance to the slab.

This slab system (designated by PreSlabTec) includes a SFRC deck of 40 mm thickness and lightweight blocks for serving as permanent moulds to the SFRC and for thermal insulation. The transversal stiffness is assured by thin wall tubular steel profiles that remained anchored in the girders due to their openings.

PreSlabTec is simple and fast of executing and was conceived for being produced in an automation process of prefabrication industry.

The efficiency of the PreSlabTec was assessed for serviceability and ultimate limit state design conditions by testing experimentally almost real scale prototypes in creep, monotonic and dynamic loadings, in ambient and fire scenarios, and executing and testing a real-scale modular building.

Despite the adoption of loading conditions for inducing shear failure, this never occurred, and the prototypes presented very ductile failure modes and aimed stiffness and load-carrying capacity, with relatively low content of resources.

A dedicated software, with an efficient user interface, was developed to propose the optimum (from the technical and economic point of view) PreSlabTec slab for the geometry and loading conditions provided by the user.

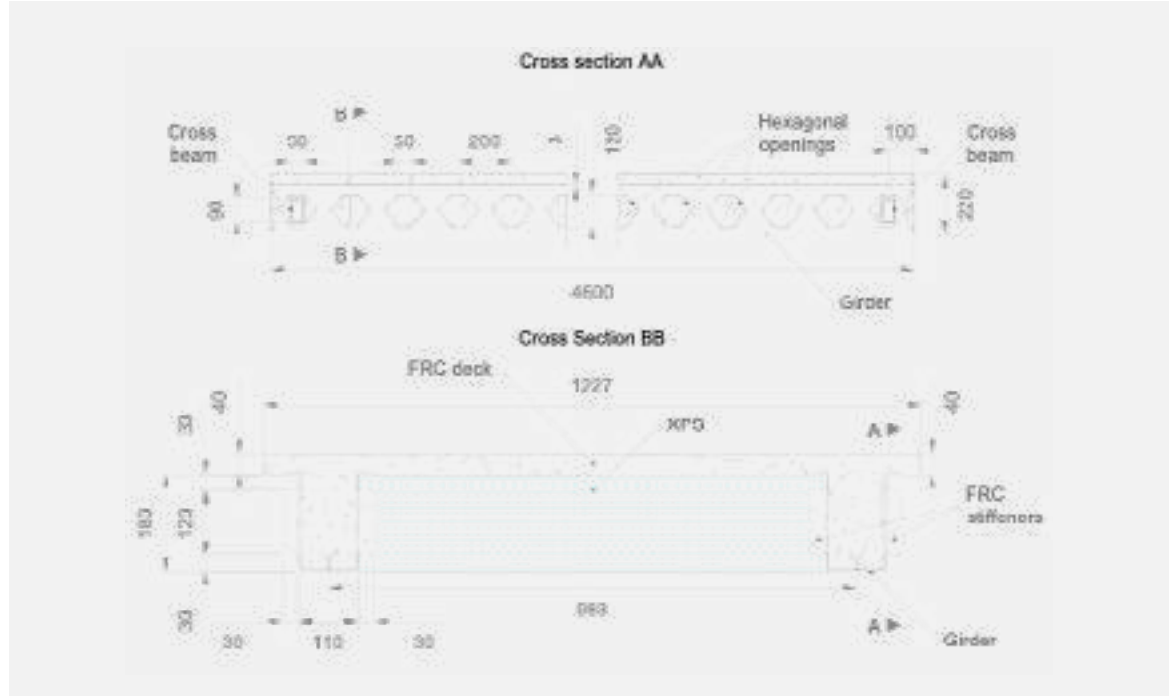

Geometry and dimensions of one of the tested prototypes (in millimetres).



Building a real scale facility with a pavement made by PreSlabTec slab modules.

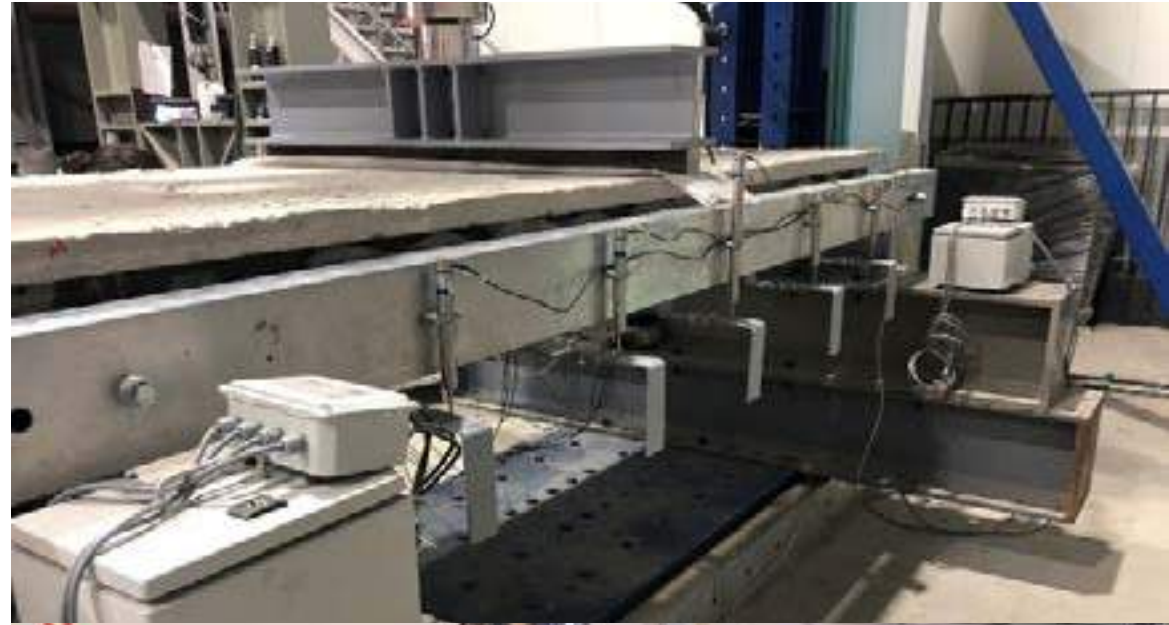

Photographs of PreSlabTec prototypes tested in: bending (left), and shear (right).



SeaPower

Association for the development of the economy of the sea

Sea and Blue Economy

The oceans are a unique resource, supporting numerous activities such as: fishing and aquaculture, maritime transport, energy production, carbon sink, tourism, construction and ship repair, among many other traditional or emerging activities.

Furthermore, the oceans play a key role in combating climate change. However, in order to take full advantage of the existing resources, it is essential to increase the knowledge about them.

It is therefore important to promote the implementation of R&D projects in the most diverse, and fundamental, areas for the support and development of business activities related to the Economy of the Sea.



Within this topic, the University of Coimbra created the SEAPOWER project, which counts with the creation of a centre for Technology and Innovation related to the field of the Sea and Blue Economy was created in Figueira da Foz, in Coimbra.

This project has the aim to develop RD&I skills in the field of the Sea and Blue Economy, having as main lines of action the development of innovative materials, design, decarbonization, digitization of the economy, autonomous vehicles (naval drones), ocean sensing, 3D printing applied to the Naval, Offshore and Energy industry.

Furthermore, is the project's intention to act in several different sectors related to the Sea Economy, such as: i) energetic transition, ii) Data Streaming e Big Data Analytics, iii) Digital Twin and iv) Green Deal.

Apart from the University of Coimbra (president Prof. Luís Simões da Silva), the funding entities of the project are the MARLO Transport and Logistic Consultants, Xsealence, IYB and BoomPlus.

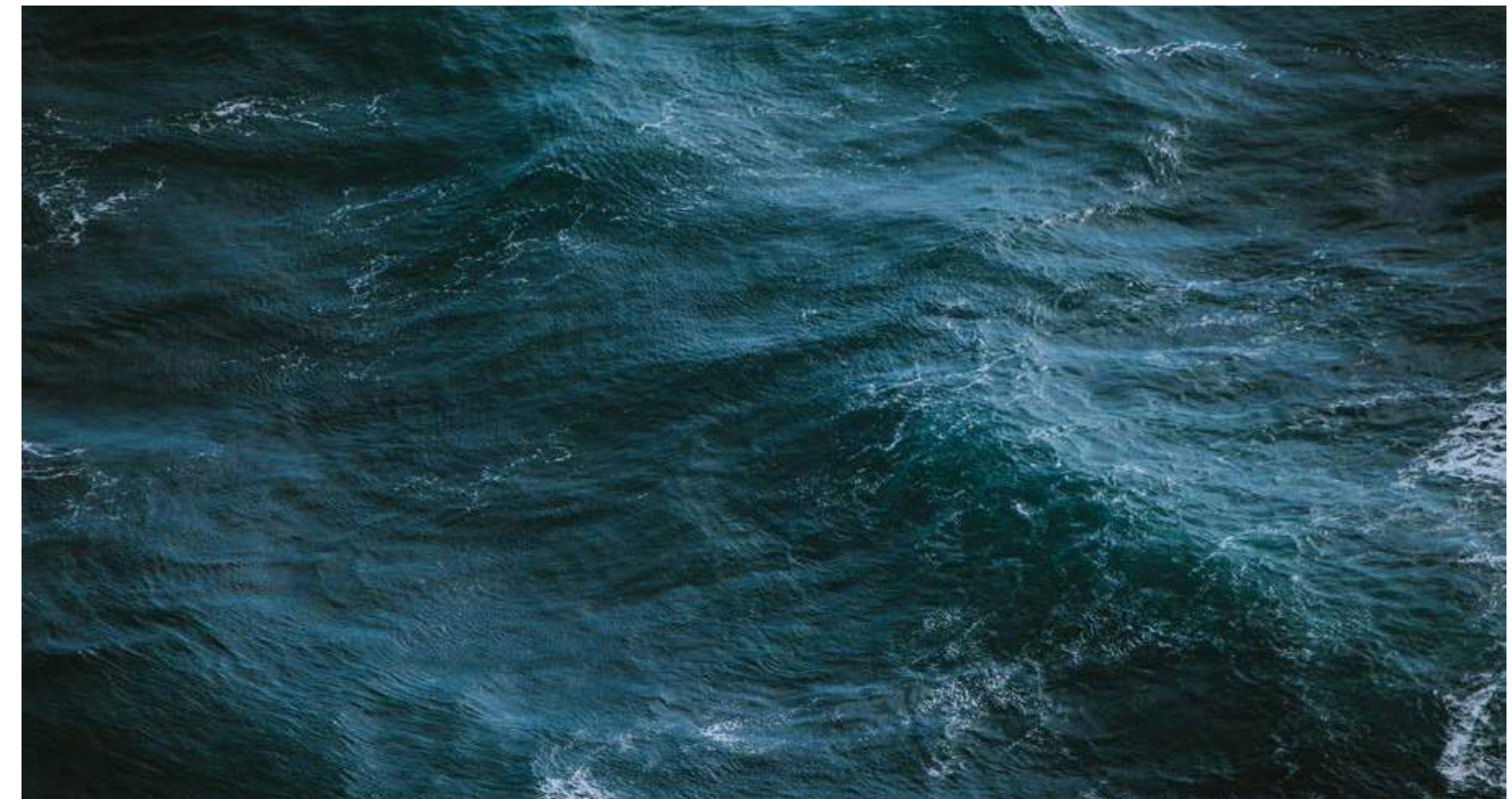



Institute for Sustainability and
Innovation in Structural Engineering

DIRECTORS

Paulo B. Lourenço
Luís Simões da Silva

ASSISTANT DIRECTORS

José Sena-Cruz
Carlos Rebelo

HISTORICAL AND MASONRY STRUCTURES

Paulo B. Lourenço

STEEL AND MIXED CONSTRUCTION TECHNOLOGY

Luís Simões da Silva

STRUCTURAL COMPOSITES

Joaquim Barros

FUNCTIONAL PERFORMANCE

Luís Godinho

SCIENCE COMMUNICATION

Francisca Santos
Miguel Azenha

CAREER DEVELOPMENT

Sofia Knapic

ADVISORY COMMITTEE

Bill F. Spencer, University of Illinois, Urbana-Champaign – USA

David A Nethercot, Imperial College London – UK

Francesco Asdrubali, Università degli Studi Roma Tre – Italy

Henrik Stang, Technical University of Denmark – Denmark

Contact Us

Need more information? Send us an e-mail:
info@isise.net



University of Coimbra

Departamento de Engenharia Civil
Faculdade de Ciências e Tecnologia

Rua Luís Reis Santos – Pólo II
3030-788 Coimbra, Portugal

+351 239 797 260

isise@dec.uc.pt

www.fct.uc.pt



Universidade do Minho
Escola de Engenharia

University of Minho

Departamento de Engenharia Civil

Campus de Azurém
4800-058 Guimarães, Portugal

+351 253 510 200

isise@civil.uminho.pt

www.civil.uminho.pt

